

COMPONENT REPLACEMENT

THROWING WHEEL REPLACEMENT

1. Turn the on/off switch "OFF" and unplug the power cord. For the bottom throwing wheel, remove 6 bolts holding the wheel guard to the main casting.
2. Hold the wheel so that it cannot move. Turn the keyway retaining bolt counter-clockwise using a box end wrench.
3. Remove the bolt and washers.
4. Work the wheel off of the motor shaft. Be sure to catch the key as it is freed from the keyway.
5. Ball throwing wheels are machine balanced. Small holes in the side of the wheel are applied at the factory and are normal. A slight wobble is normal.

Reassemble in reverse order.

- a. Install wheel to motor shaft with key slots aligned.
- b. Be sure the key is in place, and inserted so that it is flush with the boss at the wheel center.
- c. Be sure the washer and lock washer are installed in the right order, and that the keyway retaining bolt is tightened.
- d. Test the wheel by spinning it by hand and making sure that it spins freely without wobble before turning the unit "ON".
- e. Be sure the wheel guard is properly and securely reinstalled.

MOTOR REPLACEMENT

1. Turn the on/off switch "OFF" and unplug the power cord.
2. Remove the throwing wheel (see above).
3. Remove four screws holding controller into main casting. Note the position of the motor wires on the controller, then disconnect the wires. See Figure 10 on page 12.
4. Note the routing of the motor wires. Loosen any wire clamps.
5. Remove four bolts holding the motor to the main casting. See Figures 7 and 8 below.

Reassemble in reverse order.



Hold wheel while loosening bolts.

NOTE: On the bottom wheel, the Front wheel guard (part 43 on page 13) must be removed prior to the removal of the motor or ball-throwing wheel

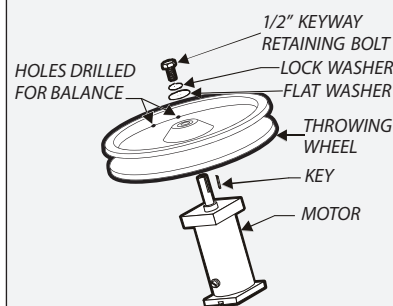

When replacing the motor, you will see two sets of bolts:

2 - 1/4" x 1 1/4" coarse thread bolts

2 - 5/16" x 1 1/2" coarse thread bolts

The wrench or socket size needed for the 1/4" bolt is a 7/16".

The wrench or socket size needed for the 5/16" bolt is a 1/2".



Figure 7 Shown using a 6" extension with 1/2" socket.



Figure 8 Shown using a 6" extension with 7/16" socket.

NOTE: Check bolts for tightness once a season. Tighten bolts securely, but do not over-tighten.

COMPONENT REPLACEMENT (cont'd)

CONTROLLER REPLACEMENT

1. Turn the on/off switch "OFF" and unplug the power cord.
2. Remove four screws holding controller faceplate into main casting. Note the position of the main power and motor wires on the controller, then disconnect the wires. See Figure 10 on page 12 for the three motor wires. See Figure 11 on page 12 for the main power cord wires.
3. Loosen the nuts holding the three speed control shafts to the faceplate, then remove the controller.

Reassemble in reverse order.

Be sure wires are correctly reinstalled. Motor wire connectors are different sizes. Be sure they are installed on the correct size terminal. See Figure 10 for the motor wires and Figure 11 for the power cord wire.

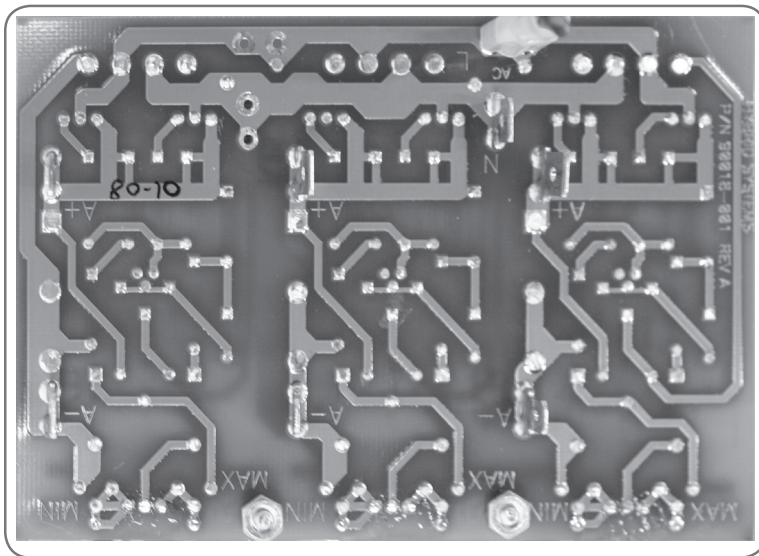

Figure 9 Wiring diagram from the control board side.

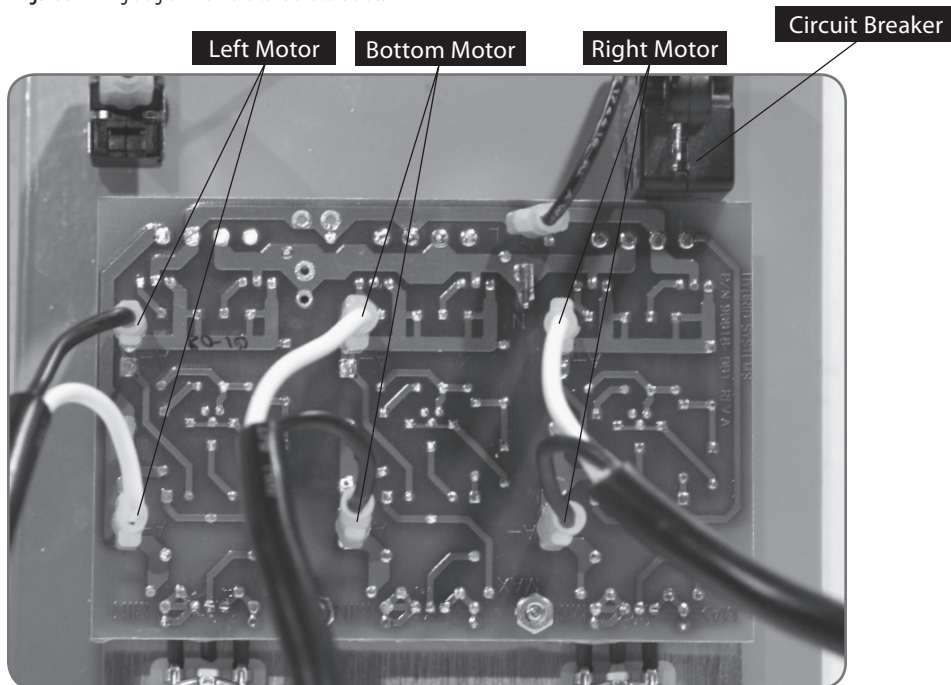

Figure 10 Wiring diagram for all three motors.

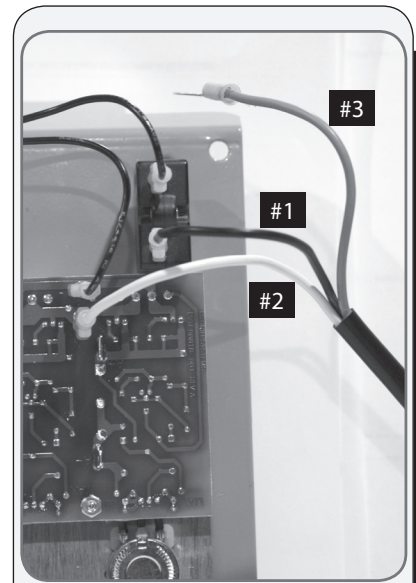

Figure 11

WIRING

POWER CORD

White or Blue Wire (1)

To middle male terminal marked "N."

Black or Brown Wire (2)

To circuit breaker.

Green Wire (3)

Grounds to machine/motor.

MOTOR WIRE LEADS

White 3/16" wide connectors.

Black 1/4" wide connectors.

Black Wire (2) connects to A- on circuit board.

White Wire (2) connects to A+ on circuit board.

CONTROLLER

Black Wire (2) 2 PR jumper wire:

- 1 from on/off switch to circuit breaker

- 1 from on/off switch to circuit board terminal "L".

CONNECTING WIRES

| Motor | Black Wire | White Wire |
|--------|------------|------------|
| Right | A- | A+ |
| Left | A+ | A- |
| Bottom | A- | A+ |

Black motor wires are 3/16" female disconnect and white wires are 1/4" female disconnect.