

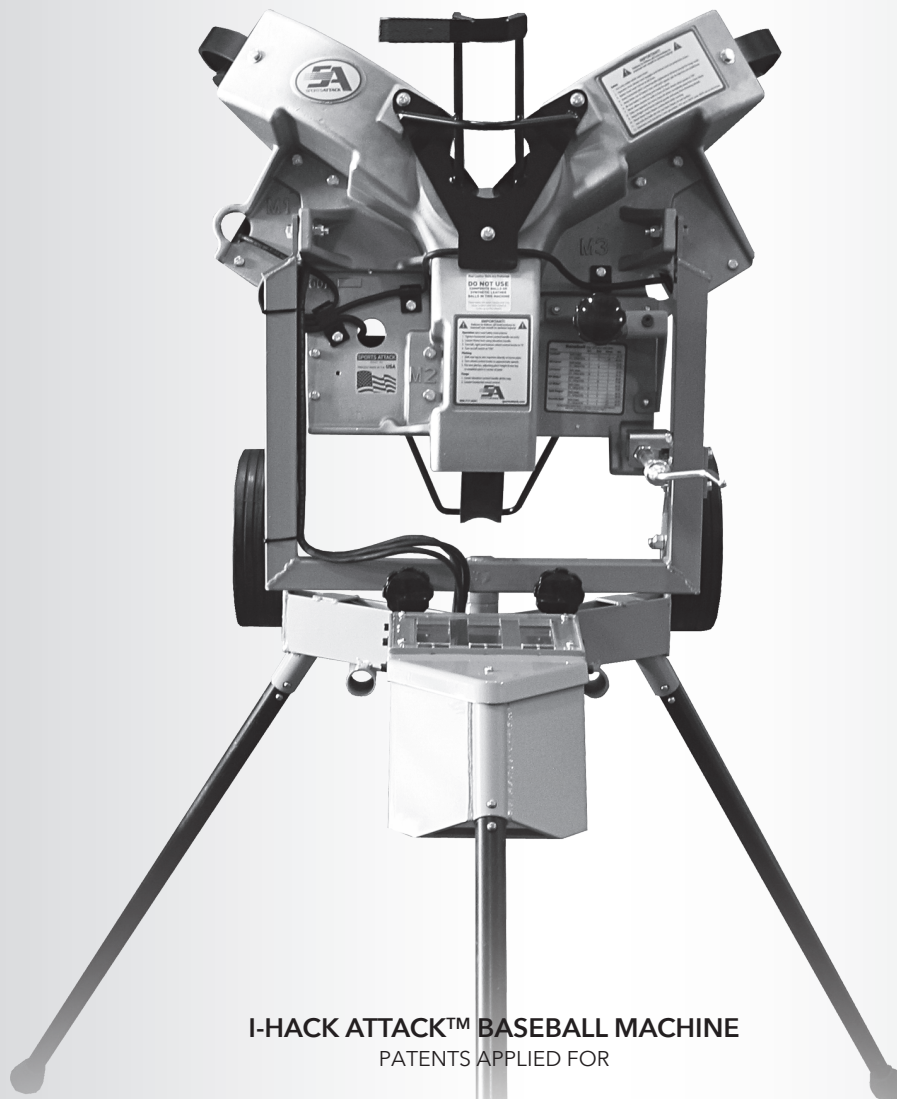

BASEBALL PITCHING MACHINES



I-HACK ATTACK™ BASEBALL MACHINE
PATENTS APPLIED FOR

INSTALLATION MANUAL

OPERATION · SETUP · USE & CARE · SERVICE



SPORTS ATTACK LLC. | 800.717.4251 | www.sportsattack.com

REV03182024

BASEBALL

WARRANTY STATEMENT

What is most important to Sports Attack is that your machine meets your expectations and represents our high standards of quality and performance. No matter the circumstances, if this is not the case, we encourage you to call our customer service department at 800.717.4251.

Warranty:

Residential & Institutional

We stand behind the material and workmanship of our machines as well as all wear components (i.e., throwing wheels, controllers, and motors) for a period of two (2) years from the date of original purchase based on the serial number and date codes on the unit.

Commercial

We stand behind the material and workmanship of our machines as well as all wear components (i.e., throwing wheels, controllers, and motors) for a period of one (1) year from the date of original purchase based on the serial number and date codes on the unit.

Requirements of the Warranty

- Warranty wear components such as motors, controllers and wheels may now require a picture or live video when submitting your request.
- The serial number that represents the date of original shipment must be legible on the Product, it cannot be removed or altered in any way.
- All date codes on unit components must be legible, not removed or altered in any way.
- If warranty components have previously been provided by Sports Attack for the unit, video evidence of their use on the machine must be provided when submitting your request.

Not Included in this Warranty:

- Normal wear and tear;
- Cosmetic damage (i.e., minor scratches, surface deformations, or discolorations) including natural fading of colors;
- Damage caused by misuse, abuse, accident or negligence including prolonged exposure to inclement weather;
- Damage caused by fire, flood or any other Act of God;
- Unauthorized modification or alteration of a machine including the use of non-authorized, after market components; and
- Any damage or failure arising after the warranty period.

The Warranty Process

If you encounter any issues during the warranty period, Sports Attack will quickly get your machine back in working order. To submit a warranty request, you must call our customer service department at 800.717.4251. If the warranty repair involves a replacement part, we will make sure you get both the part and easy instructions for replacement at no cost to you.

Returns

Sports Attack manufactures the highest quality sports training equipment in the world. If for any reason you are not satisfied, a machine can be returned within 30 days of receipt, for any reason, for a full refund less a 15% restocking fee. Cost of shipping the unit back to Sports Attack will also be the responsibility of the purchaser. Please note that the refund amount may be reduced by any non-cosmetic damage to the machine.

Please call customer service department at 800.717.4251 for returns.

SHIPPING DAMAGE CLAIMS PROCEDURE

NOTE: For your protection, please note that equipment in this shipment was carefully inspected and packaged by skilled personnel before leaving the factory.

Upon acceptance of this shipment, the transportation company assumes full responsibility for its safe delivery.

(cont. on page 1)

To register the Warranty, please go to our website:

www.sportsattack.com/warranty

For repairs and service after the Warranty period, please call:

**Sports Attack
Customer Service Dept.**

Ph 800.717.4251

Fx 775.345.2883

RETURNS

To return an item, please contact our Customer Service Department at 800-717-4251.

A 15% restocking fee will be charged for any items accepted for return. It is the customer's responsibility to handle the repacking and shipment (as well as all associated fees) back to Sports Attack.

No returns will be accepted after 30 days of receiving product.

IF SHIPMENT ARRIVES DAMAGED:

1. **VISIBLE LOSS OR DAMAGE:** Be certain that any visible loss or damage is noted on the freight bill or express receipt, and that the note of loss or damage is signed by the delivery person.
2. **FILE CLAIM FOR DAMAGE IMMEDIATELY:** Regardless of the extent of the damage.
3. **CONCEALED LOSS OR DAMAGE:** If damage is unnoticed until the merchandise is unpacked, notify the transportation company or carrier immediately, and file "CONCEALED DAMAGE" claim with them. This must be done within fifteen (15) days from the date the delivery was made to you. Be sure to retain the container for inspection.

Sports Attack, LLC. cannot assume liability for damage or loss incurred in transit. We will, however, at your request, supply you with the necessary documents to support your claim.

INTRODUCTION

Thank you for purchasing this Sports Attack, LLC. equipment.

Proper assembly, careful operation and consistent maintenance of this equipment will ensure that it gives you the very best performance and a long, economical service life.

This manual contains the information needed to properly set up the I-Hack Attack Baseball Pitching Machine, and to use, care for and maintain the I-Hack Attack in a manner which will ensure its optimum performance.

TABLE OF CONTENTS

Warranty Statement xi

Safety Instructions 2

I-HACK ATTACK BASEBALL MACHINE OPERATION

 Features & Operating Controls 4

 Set-up & Preparation 5

 Batting Practice 6

 Fungo (Fielding Practice) 8

 Shutting Down 9

MAINTENANCE & SERVICE

 Care, Cleaning & Maintenance 10

 Component Replacement 11

 Exploded View 13

 Parts List 14

 Conversion, Baseball to Softball 15



SAFETY INSTRUCTIONS

ELECTRICAL SAFETY

Use a 115 volt single phase 3-wire (2 wire with ground) grounded power source.

Up to 200 ft. from power source, use a minimum #14/3 grounded 3-wire 15 amp minimum rating extension cord.

Over 200 ft. from power source, consult a licensed electrician for required power cord size.

OPERATING SAFETY

CAUTION: Never reach down near moving throwing wheels for any reason! If it is necessary to reach into the throwing wheels, **ALWAYS:**

1. Turn all three speed dials to "0".
2. Turn on/off switch "OFF".
3. Unplug I-hack Attack from power source
4. Wait until the throwing wheels have come to a complete stop before reaching hands or fingers anywhere near the throwing wheels.

CAUTION: Carefully check I-Hack Attack for completeness and condition before connecting to electrical power:

1. Throwing wheels must be tight on the motor shafts
2. Wheel guard and ball chute must be tightly fastened to the throwing head.

Carefully check the throwing wheels frequently for cleanliness, chips and cracks. Do not use the machine if the throwing wheels are damaged, or if chips or cracks appear in the wheels. (For damage within Warranty period, see Warranty Statement, page i.)

ALWAYS set the speed controls to "0" before connecting the machine to power. Check that the speed controls are at "0" before turning the on/off switch "ON."

Do not allow anyone to walk in front of the machine if it is connected to electrical power.

WARNING PERSONAL INJURY HAZARD

Carefully read all instructions in this manual, and all labels and warnings on I-Hack Attack before using this machine.

Use machine only under adult supervision. Failure to operate I-Hack Attack as described in this manual can result in severe personal injury or death.

Never loosen the horizontal swivel lock while pitching to a batter. If the lock is not secure, the throwing head could pivot.

A loose swivel lock can allow a pitch to be inside which could hit the batter.

ELECTRICAL SHOCK HAZARD

I-Hack Attack must be connected to a properly grounded electrical receptacle.

Do not operate on wet ground.

CAUTION PERSONAL INJURY HAZARD

Keep hands away from throwing wheels anytime the machine is connected to a power source.

Carefully check I-Hack Attack for completeness and condition before connecting to electrical power.

EQUIPMENT ELECTRICLDAMAGE

Keep hands away from throwing wheels anytime the machine is connected to a power source.

Carefully check I-Hack Attack for completeness and condition before connecting to electrical power.

SAFETY INSTRUCTIONS (cont'd)

BALL SELECTION

Never mix leather balls with synthetic pitching machine balls.

Be careful not to mix new with old balls or balls from different manufacturers.

Balls must be consistent in type and amount of wear to produce repeatability.

Never use wet balls!

BATTING PRACTICE

The horizontal swivel lock must be securely tightened before the batter approaches the plate.

ALWAYS test and adjust the I-Hack Attack before a batter steps up to the plate:

1. Adjust so that I-Hack Attack throws a ball across the plate.
2. Throw test pitches until required velocity and break are reached.
3. Throw several pitches to verify pitch location repeatability.

DO NOT make any speed or pitch location changes while the batter is at the plate.

Batter and pitching machine operator must wear batting helmets.

Only one person at a time should operate the machine.

Always present the ball to the batter before feeding the ball into the machine.

Operator must stand behind a protective screen to prevent injury from balls off the bat. Screen is not included with I-Hack Attack.

FIELDING PRACTICE

Both the elevation control and swivel lock must be released so that the throwing head moves freely through the intended range of motion.

Never reach up chute to push ball into the throwing wheels.

Keep hands and fingers well away from the throwing wheels.

Be careful to keep all persons away from in front of I-Hack Attack.

For best accuracy, use dimpled pitching machine balls.

NOTE: Vertical (elevation control) must be adjusted whenever you change pitches (spins).

Knuckle Balls thrown too fast are dangerous and unrealistic!

CAUTION PERSONAL INJURY HAZARD

ALWAYS use a protective screen to protect the operator from the ball off the bat. (Screen not included with I-Hack Attack.)

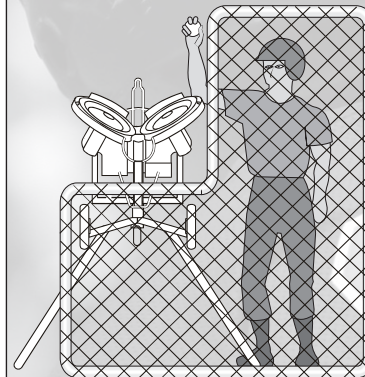

ALWAYS wait for all three throwing wheels to come to a complete stop before transporting I-Hack Attack, lifting the throwing head or performing any repairs.

ADDITIONAL INFORMATION

If you have any questions regarding the safe operation of this equipment, please call:

Sports Attack Customer
Service Department
Ph 800-717-4251
Fx 775-345-2883

FEATURES & OPERATING CONTROLS

I-HACK ATTACK BASEBALL PITCHING MACHINE PATENTS APPLIED FOR

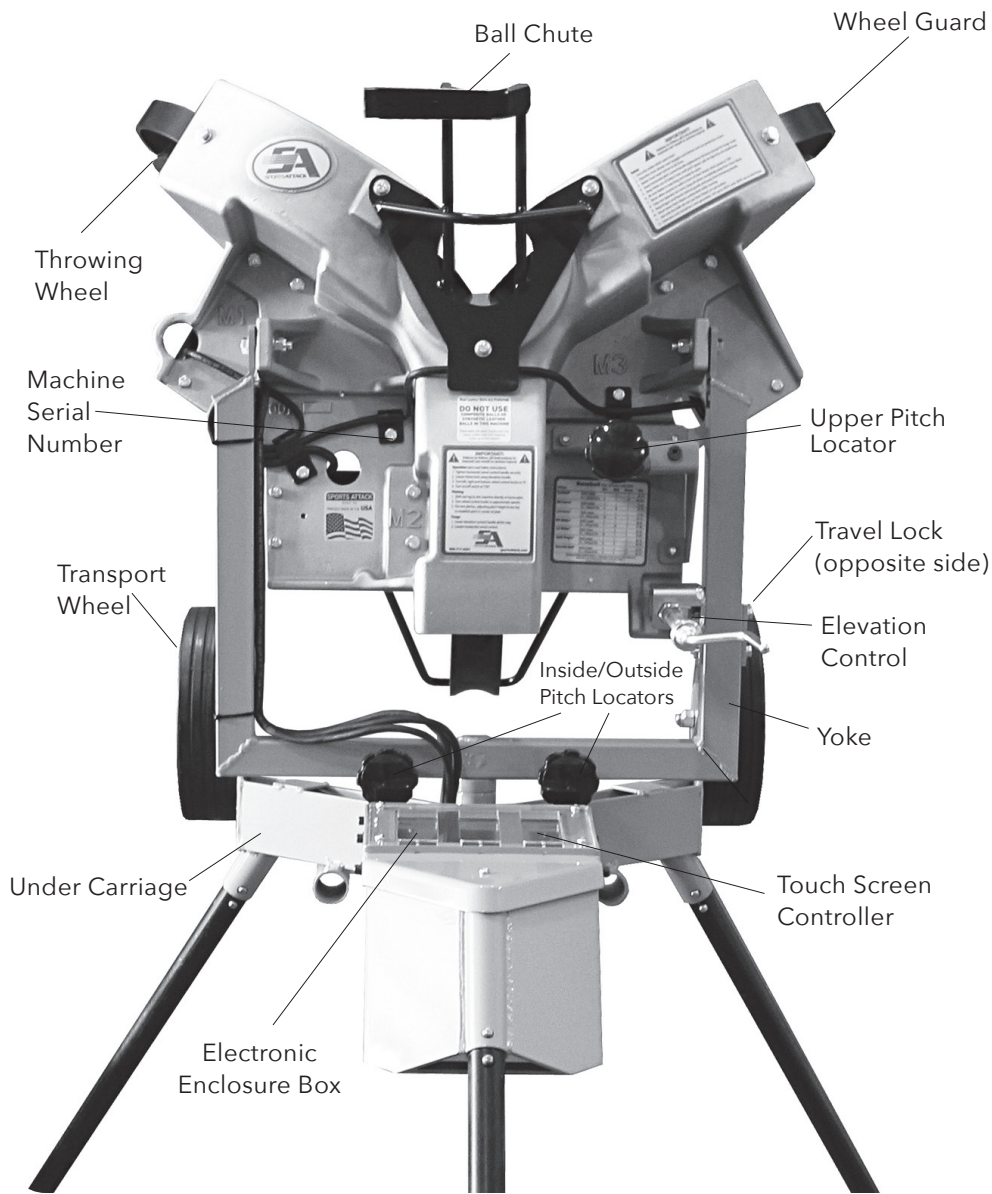

Figure 5

Travel lock must be secure prior to movement.



Figure 1 Position I-Hack Attack



Figure 2 Tip up onto wheel guard; Insert two front legs



Figure 3 Set I-Hack Attack upright



Figure 4 Carefully tilt I-Hack Attack up onto its legs

Features & Operating Controls

SAFETY HINT

Keep your back straight and lift with your legs. Be ready to grab the wheel guard and guide I-Hack Attack into the upright position.

SET-UP & PREPARATION

1. Install the rear leg (**NOTE:** the leg has a push button, which locks the leg into the socket). Roll I-Hack Attack onto the mound approximately four feet in front of the rubber.
2. Be sure the pitch locator's are tightened securely.
3. Tilt I-Hack Attack forward until it rests on the throwing wheel guard.
4. Insert the two front legs into the front sockets in the undercarriage (**NOTE:** the front legs also have locking push buttons).
5. See Figure 2 on page 4.
Walk around to the front of I-Hack Attack, and, with your back to home plate, reach down and grasp the wheel guards. Then, lift I-Hack Attack up and over the front legs and set it gently onto the rear leg.
6. Position I-Hack Attack:
 - a. To approximate the release point of a live pitcher, position I-Hack Attack so that the rear leg is just in front of the rubber.
 - b. Then, sight down ball chute. Move the rear leg right or left to adjust machine so that it is pointing directly at home plate.
 - c. Check the pitch locator's to make sure it remains tight.
7. Unlock the travel lock. Turn the handle of the elevation control counter-clockwise until the bar of the travel lock snaps back out of the way.
8. Adjust the throwing head:
 - a. Turn the handle of the elevation control clockwise. Raise the throwing head until it will throw somewhere near the required height.
 - b. This initial adjustment will come through experience. To start, turn the elevation adjustment 10 turns clockwise.
9. Examine I-Hack Attack for condition and completeness:
 - a. Be sure the pitch locator's are secured.
 - b. Throwing wheels must be tight on the motor shafts. Check that the keyway retaining bolts are tight.
 - c. Wheel guard and ball chute must be securely fastened to the throwing head.
10. Be certain on/off switch is turned "OFF"; then plug I-Hack Attack into an extension cord or other power source. (See generator information at right if applicable.)

WARNING

HAZARD FROM HIGH-SPEED PROJECTILES

Being struck by a pitched ball can cause serious injury or death. Make sure that no one steps in front of I-Hack Attack while it is connected to electric power.

Clear all hitters away from home plate, the batter's box and the backstop area before connecting I-Hack Attack to electric power.

GENERATOR INFORMATION

1. I-Hack Attack requires a generator capable of providing clean electricity at a minimum of 1200 watts at 120 volts 60hz.
2. Be sure the on/off switch is "OFF" before plugging I-Hack Attack into the generator.
3. Start the generator and allow it to reach full speed before turning the on/off switch "ON".

IMPORTANT: Generator speed fluctuations can damage the electronic speed control. Maintain adequate fuel in the generator at all times.

4. Turn the on/off switch "OFF" before shutting off the generator and before unplugging I-Hack Attack.

PITCH LOCATORS

Pitch Locators Purpose

Pitch locators adjust to limit change in the movement of the throwing head defining the location of the pitch: inside/outside and high/low or locked for repeatability.

There are three pitch locators and an elevation handle. Two pitch locators, left pitch locator (LPL) and right pitch locator (RPL) control the amount of horizontal (inside/outside) pitch location. (See Figure 6).

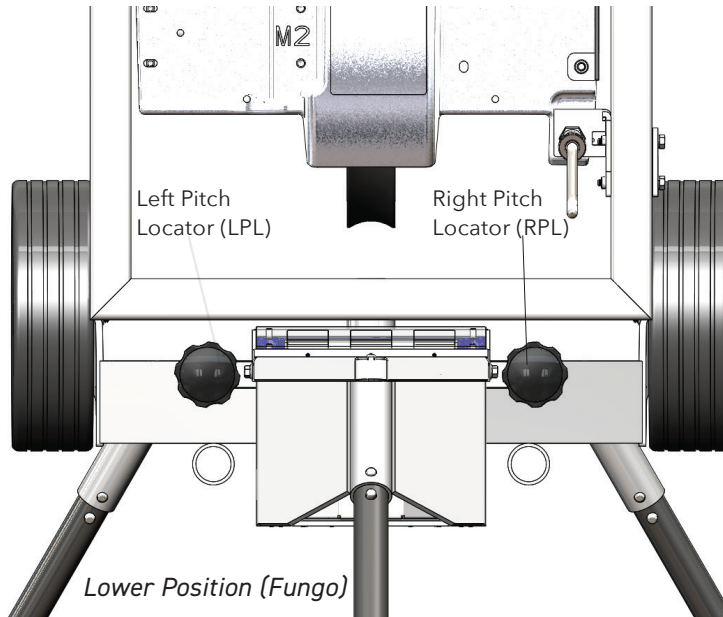

Figure 6

Pitch Locators Functions

Locators in raised position

1. To locate pitch inside and outside for change in the hitters strike zone (See Figure 7).
2. Allow for wider pitches for catcher's blocking drills (See Figure 7).
3. To allow head to be locked in position for pitch location repeatability. (See Figure 7).
4. To allow for balls to be thrown across width of infield or outfield for around balls/fly balls (fungo) for defensive work (See pic above).

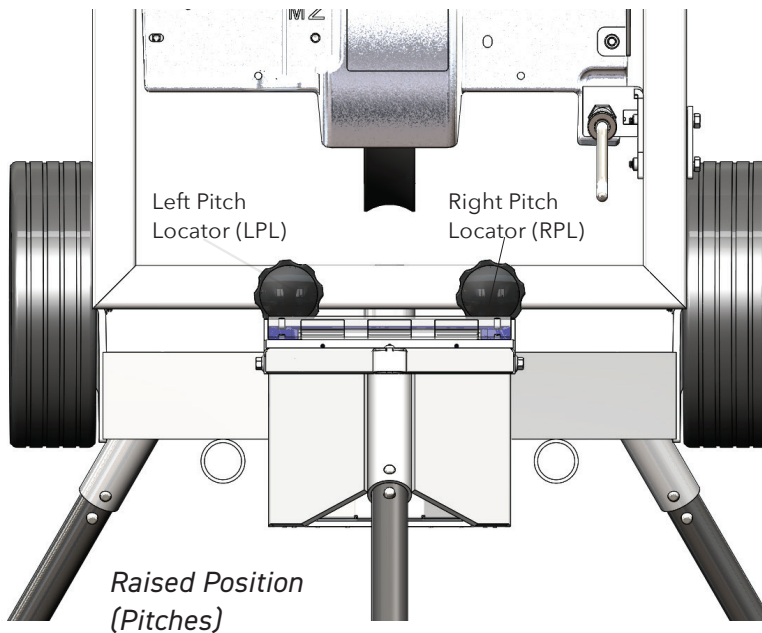

Figure 7

WARNING HAZARD FROM HIGH-SPEED PROJECTILES

Being struck by a pitched ball can cause serious injury or death. Make sure that no one steps in front of I-Hack Attack while it is connected to electric power.

Clear all hitters away from home plate, the batter's box and the backstop area before connecting I-Hack Attack to electric power.

NOTE: As wheel speeds are changed for different velocities and spins, the ball will be pitched to differing locations. Compensate for these changes by turning the elevation control, and by moving the rear leg.

Figure 3 Present the ball to the hitter



Feeding the ball

IMPORTANT: Hitter should stride the instant he sees the ball release from the feeder's hand at the upper end of the ball chute.

PITCH LOCATORS -cont'd

When pitch locators (LPL & RPL) are in Locating Position (Figure 8) and test pitch is centered on home plate both left (LPL) and right (RPL) pitch locators are firmly up against yoke at **(A)** and **(B)** throwing head is locked in position for pitch location repeatability.

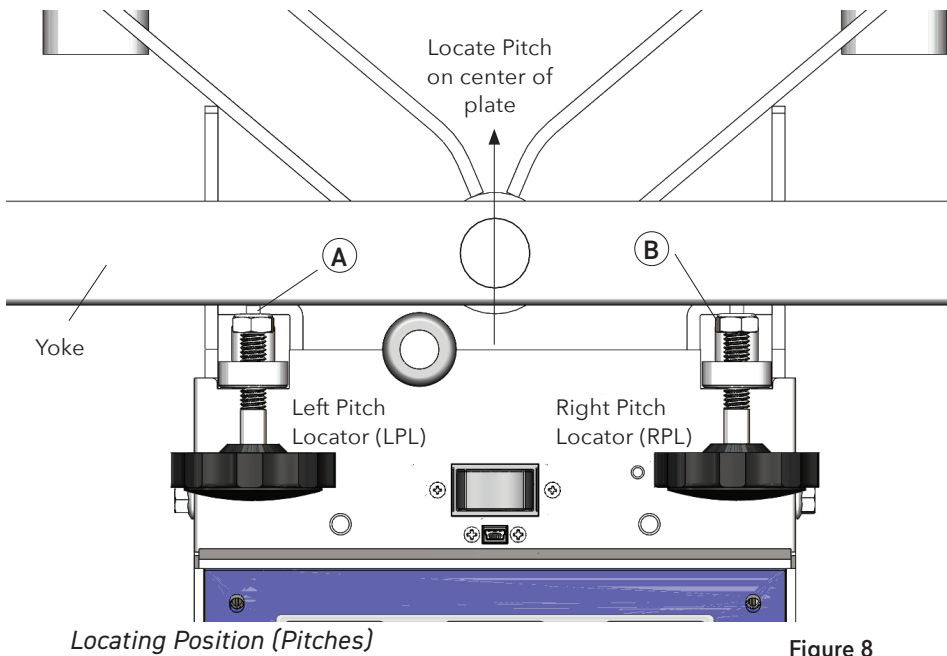

Figure 8

When LPL is backed off (loosened) at **(A)** (Figure 9) and RPL remains at **(B)** position pitch location will be outside.

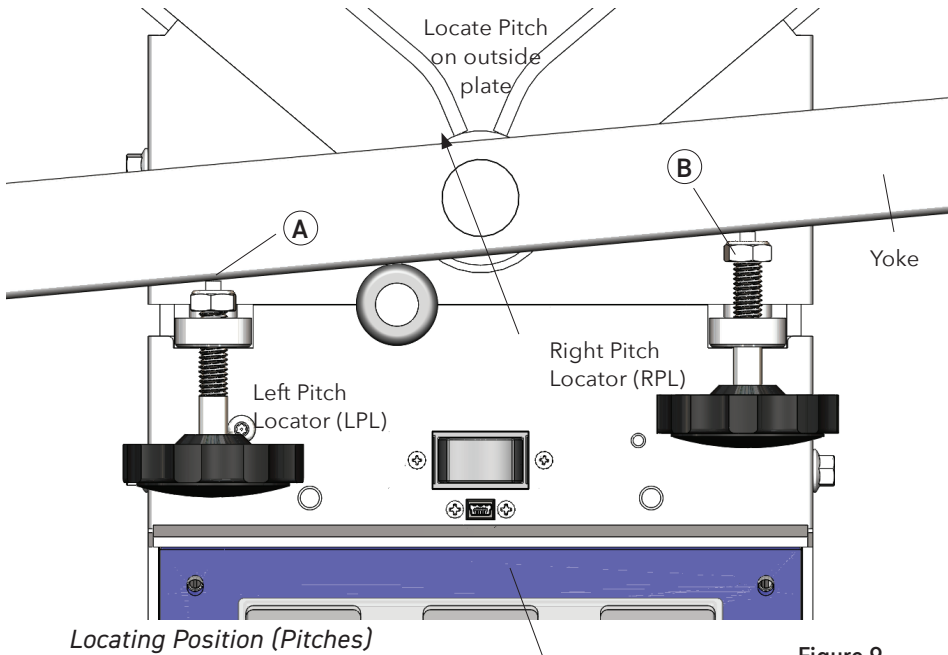

Figure 9

Serial number of electronic control box

WARNING HAZARD FROM HIGH-SPEED PROJECTILES

Being struck by a pitched ball can cause serious injury or death. Make sure that no one steps in front of I-Hack Attack while it is connected to electric power.

Clear all hitters away from home plate, the batter's box and the backstop area before connecting I-Hack Attack to electric power.

NOTE: As wheel speeds are changed for different velocities and spins, the ball will be pitched to differing locations. Compensate for these changes by turning the elevation control, and by moving the rear leg.

Figure 3 Present the ball to the hitter



Feeding the ball

IMPORTANT: Hitter should stride the instant he sees the ball release from the feeder's hand at the upper end of the ball chute.

PITCH LOCATORS -cont'd

When RPL is backed off (loosened) at **(B)** and LPL remains at **(A)** (Figure 10) pitch position will be inside.

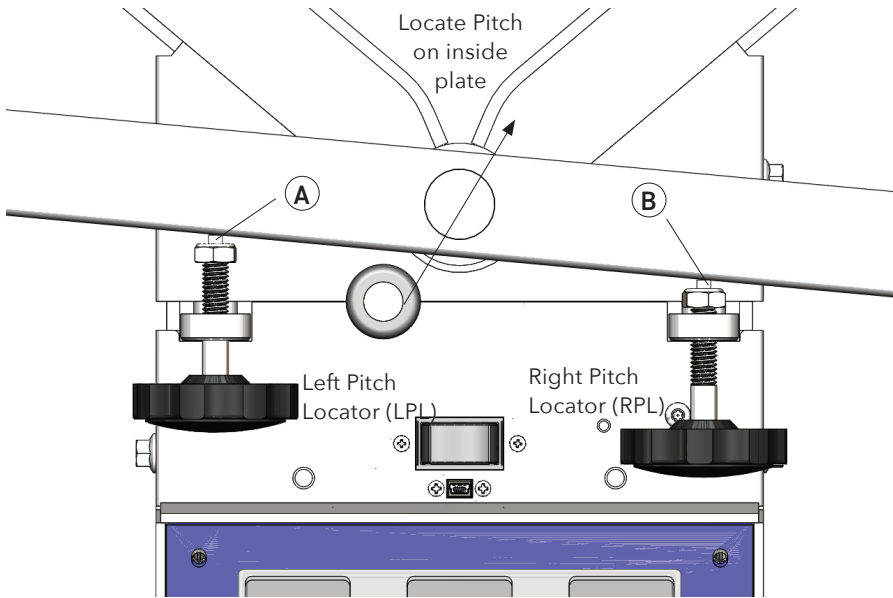
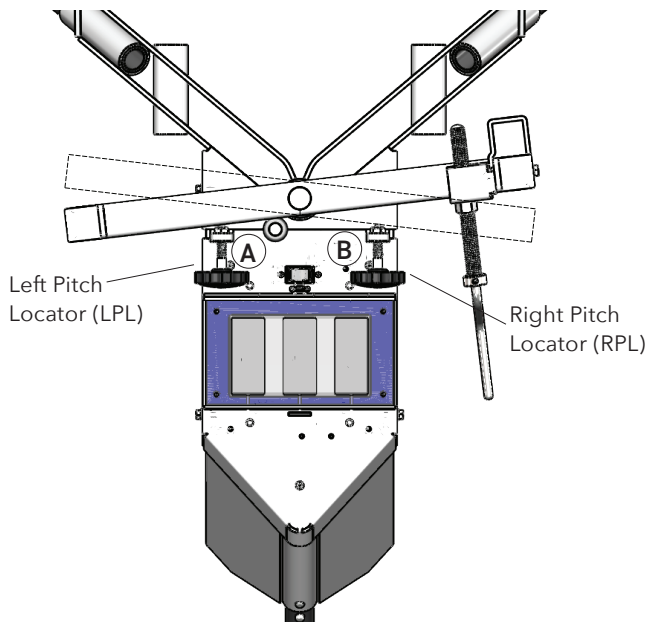

Figure 10

When both pitch locators (LPL and RPL) are backed off (loosened) (Figure 11) **(A)** **(B)**, pitch location can now be moved either inside or outside between pitches.



Locating Position (Pitches)

Figure 11

WARNING HAZARD FROM HIGH-SPEED PROJECTILES

Being struck by a pitched ball can cause serious injury or death. Make sure that no one steps in front of I-Hack Attack while it is connected to electric power.

Clear all hitters away from home plate, the batter's box and the backstop area before connecting I-Hack Attack to electric power.

NOTE: As wheel speeds are changed for different velocities and spins, the ball will be pitched to differing locations. Compensate for these changes by turning the elevation control, and by moving the rear leg.

Figure 3 Present the ball to the hitter



Feeding the ball

IMPORTANT: Hitter should stride the instant he sees the ball release from the feeder's hand at the upper end of the ball chute.

PITCH LOCATORS -cont'd

When pitch locators are in lowered position (Figure 12) throwing head is now free to pivot horizontally throwing across width of field for fungo work (ground balls, fly balls and pop-ups).

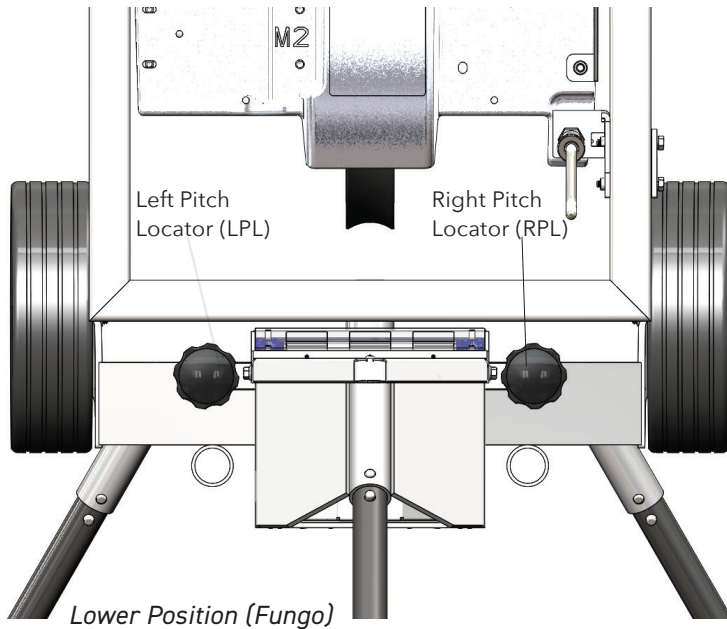

Figure 12

Similarity with upper pitch locator (UPL) in vertical pitch limit position (Figure 13) and elevation handle you can establish desired high and low pitch locations to which you can move instantly. UPL establishes desired height and elevation handle establishes low point within strike zone.

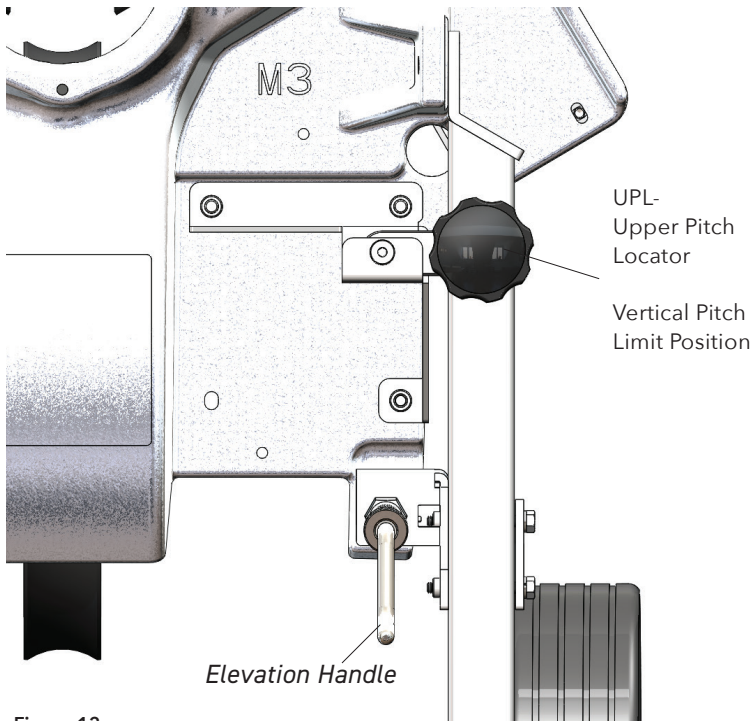

Figure 13

WARNING HAZARD FROM HIGH-SPEED PROJECTILES

Being struck by a pitched ball can cause serious injury or death. Make sure that no one steps in front of I-Hack Attack while it is connected to electric power.

Clear all hitters away from home plate, the batter's box and the backstop area before connecting I-Hack Attack to electric power.

NOTE: As wheel speeds are changed for different velocities and spins, the ball will be pitched to differing locations. Compensate for these changes by turning the elevation control, and by moving the rear leg.

Figure 3 Present the ball to the hitter



Feeding the ball

IMPORTANT: Hitter should stride the instant he sees the ball release from the feeder's hand at the upper end of the ball chute.

PITCH LOCATORS -cont'd

When UPL is flipped over (Figure 14) to free vertical limit position, throwing head can be tilted back for infield for fly balls, time drivers, infield pop-ups and catcher's pop-ups;

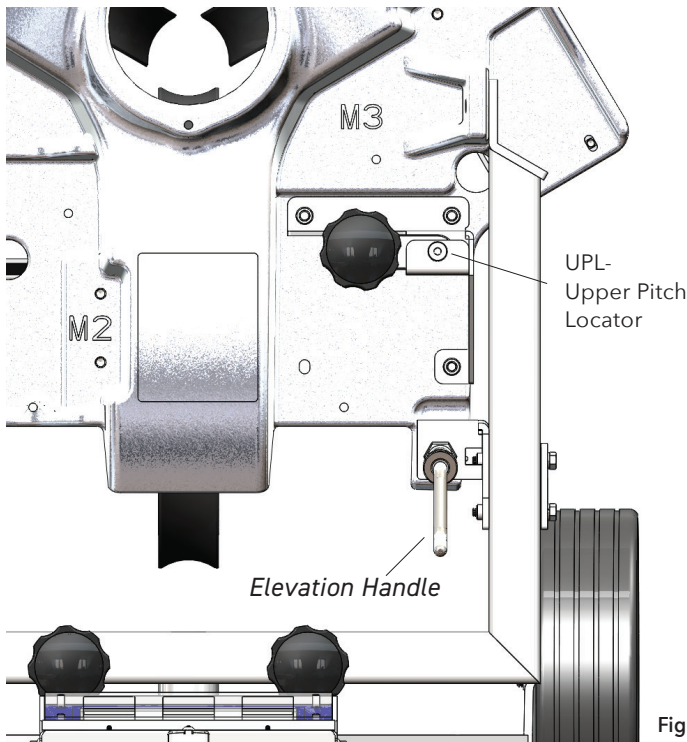

Figure 14

When both LPL and RPL are in lower position (Figure 15) and UPL (Figure 14) is in the free position (Figure 14) throwing head is free to pivot instantly in any direction to throw ground balls and fly balls to any spot on the field (fungo).

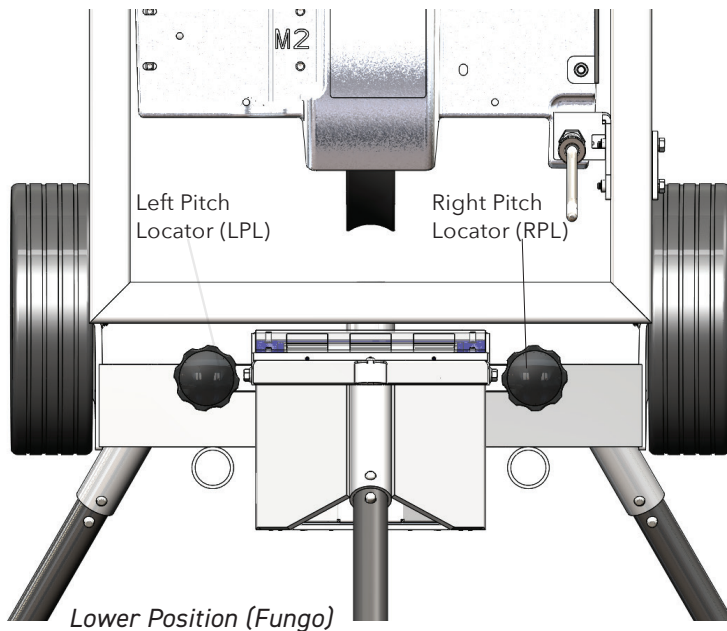

Figure 15

While complicated to describe, actual use will quickly make pitch locators effective and easy to use. These locators are exclusive to the I-Hack!

WARNING HAZARD FROM HIGH-SPEED PROJECTILES

Being struck by a pitched ball can cause serious injury or death. Make sure that no one steps in front of I-Hack Attack while it is connected to electric power.

Clear all hitters away from home plate, the batter's box and the backstop area before connecting I-Hack Attack to electric power.

NOTE: As wheel speeds are changed for different velocities and spins, the ball will be pitched to differing locations. Compensate for these changes by turning the elevation control, and by moving the rear leg.

Figure 3 Present the ball to the hitter



Feeding the ball

IMPORTANT: Hitter should stride the instant he sees the ball release from the feeder's hand at the upper end of the ball chute.

SHUTTING DOWN

TURNING I-HACK ATTACK "OFF"

1. Set each speed control dial to "0".
2. Turn the on/off switch "OFF".
3. Unplug I-Hack Attack from the power source.

PUTTING I-HACK ATTACK AWAY

1. Be absolutely sure that the throwing wheels have completely stopped turning.
2. See Figure 7 at right:
 - a. Turn the elevation adjustment counter-clockwise until the throwing head is all the way down against the elevation control nut.
 - b. Push and hold the travel lock all the way in.
 - c. Turn the elevation adjustment clockwise until the throwing head is held tightly against the travel lock. Tighten just enough to secure the throwing head. It is not necessary to over tighten.
3. Using the rear leg as a handle, tip I-Hack Attack up and over onto the wheel guard.
4. Remove (unsocket) both front legs and store by inserting in the travel storage sockets.
5. See Figure 8 at right:

Again, using the rear leg as a handle, tip I-Hack Attack back until machine can be comfortably rolled on the travel wheels. I-Hack Attack can now be rolled and maneuvered off of the field.
6. To transport I-Hack Attack in a car, remove the throwing head:
 - a. Be sure the travel lock is engaged and the throwing head is tightly secured to the yoke.
 - b. Loosen the horizontal swivel control. Turn it counter-clockwise until the throwing head is free to lift out of the swivel.
 - c. Lift the throwing head straight up and clear of the undercarriage.

SUGGESTION: The throwing head, while awkward, can be carried for short distances by gripping the top section of the wheel guard and balancing the piece against your thighs as you walk.
 - d. To prevent damage in transport, rest the throwing head on the wheel guard and yoke; motors should be down, and the control panel pointing up.

*** SEE OPERATION MANUAL FOR SYSTEM OPERATIONS.**



Storing Legs in Travel Socket

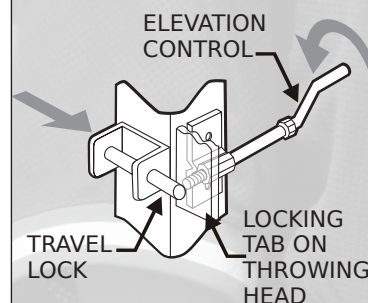

Figure 7 Secure the Travel Lock

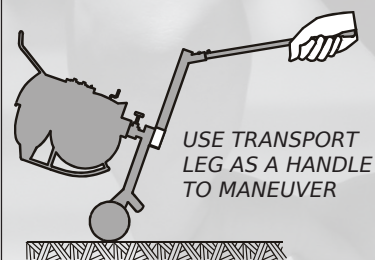

Figure 8 Maneuvering

CARE, CLEANING & MAINTENANCE

LUBRICATION (once per season, or as required):

1. Elevation Control

- a. Apply fresh grease.
- b. Reinstall, making sure that the tension spring is around the threads. (See item 30, 30B and 31 on page 13).

2. Travel Lock

Apply a small amount of grease where the pin passes through the fitting. Make sure the travel lock operates freely.

3. Horizontal Swivel Lock

- a. Completely remove the horizontal swivel lock nut. Clean all old grease, dirt, etc. from the threads.
- b. Wipe the threads with a very small amount of fresh grease.
- c. Reinstall.

THROWING WHEEL MOTORS

Motors are sealed and require no lubrication.

Check bolts for tightness once a season. Tighten bolts securely, but do not over-tighten. See Figures 7 and 8 on page 11.

CLEANING THE THROWING WHEELS

The throwing wheels must be kept clean to maintain accuracy. Clean the wheels periodically to control the build-up of grass and dirt.

1. Turn the on/off switch "OFF" and allow the wheels to come to a complete stop. Unplug I-Hack Attack from electric power.

Dampen a rag with soap and water. Turn the throwing wheel by hand and scrub the wheel until the build-up is removed. For very heavy build-up, a synthetic scouring pad, such as a Scotch-Brite® scouring pad, or medium sandpaper may be used sparingly. Methyl Ethyl Ketone (M.E.K.) may be required to help loosen the build-up of dirt or ball residue.

EXAMINE THE MACHINE

Examine I-Hack Attack for condition and completeness before every use:

1. For batting practice, be sure the horizontal swivel lock is secured.
2. Throwing wheels must be tight on the motor shafts. Check that the keyway retaining bolts are tight.
3. Wheel guard and ball chute must be securely fastened to the throwing head.

CAUTION PERSONAL INJURY HAZARD

Never attempt to clean the throwing wheels while they are turning. Rags or implements caught in spinning wheels can cause serious injury.

Unplug the machine before cleaning the wheels or performing any service.

CHEMICAL HAZARD

Methyl Ethyl Ketone (M.E.K)

Read and follow the directions and safety instructions on the M.E.K container.

FIRE HAZARD

Methyl Ethyl Ketone (M.E.K)

M.E.K. is flammable. Do not use M.E.K. around a fire or flame. Do not use M.E.K. near a running generator or other source of ignition.

COMPONENT REPLACEMENT

THROWING WHEEL REPLACEMENT

1. Turn the on/off switch "OFF" and unplug the power cord. For the bottom throwing wheel, remove 6 bolts holding the wheel guard to the main casting.
2. Hold the wheel so that it cannot move. Turn the keyway retaining bolt counter-clockwise using a box end wrench.
3. Remove the bolt and washers.
4. Work the wheel off of the motor shaft. Be sure to catch the key as it is freed from the keyway.
5. Ball throwing wheels are machine balanced. Small holes in the side of the wheel are applied at the factory and are normal. A slight wobble is normal.

Reassemble in reverse order.

- a. Install wheel to motor shaft with key slots aligned.
- b. Be sure the key is in place, and inserted so that it is flush with the boss at the wheel center.
- c. Be sure the washer and lock washer are installed in the right order, and that the keyway retaining bolt is tightened.
- d. Test the wheel by spinning it by hand and making sure that it spins freely without wobble before turning the unit "ON".
- e. Be sure the wheel guard is properly and securely reinstalled.

MOTOR REPLACEMENT

1. Turn the on/off switch "OFF" and unplug the power cord.
2. Remove the throwing wheel (see above).
3. Remove four screws holding controller into main casting. Note the position of the motor wires on the controller, then disconnect the wires.
4. Note the routing of the motor wires. Loosen any wire clamps.
5. Remove four bolts holding the motor to the main casting. See Figures 7 and 8 below.

Reassemble in reverse order.



Hold wheel while loosening bolts.

NOTE: On the bottom wheel, the Front wheel guard (part 43 on page 13) must be removed prior to the removal of the motor or ball-throwing wheel

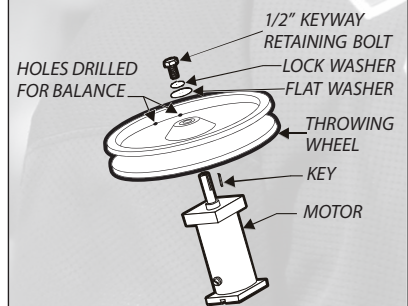

When replacing the motor, you will see two sets of bolts:

2 - 1/4" x 1 1/4" coarse thread bolts

2 - 5/16" x 1 1/2" coarse thread bolts

The wrench or socket size needed for the 1/4" bolt is a 7/16".

The wrench or socket size needed for the 5/16" bolt is a 1/2".



Figure 16 Shown using a 6" extension with 1/2" socket.



Figure 17 Shown using a 6" extension with 7/16" socket.

NOTE: Check bolts for tightness once a season. Tighten bolts securely, but do not over-tighten.

EXPLODED VIEW

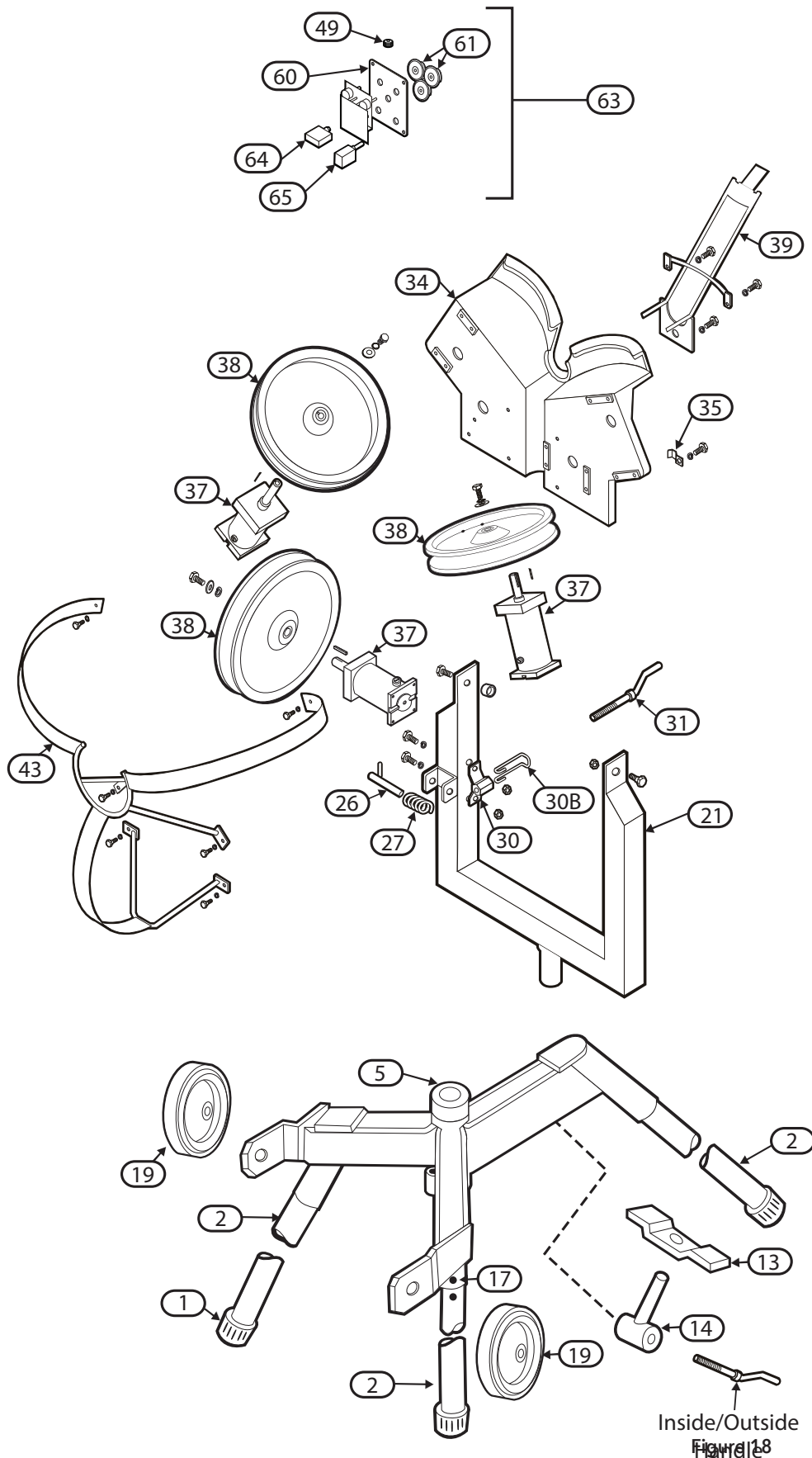

- 1 Cane Tip
- 2 Leg - Standard Size (ea.)
- 5 Undercarriage
- 13 Horizontal Swivel Lock Handle
- 14 Swivel Lock Pivot
- 17 Snap-Button
- 19 Travel Wheel (with axle, bolt, nut, washers)
- 21 Yoke
- 26 Pin, Travel Lock
- 27 Spring, Travel Lock
- 30 Fitting, Elevation Control
- 30B Tension Spring, Elevation Control
- 31 Handle, Elevation Control
- 34 Main Casting, Throwing Head
- 35 Clamp, Cable
- 36 Hinge Assembly, Throwing Head
- 37 Motor, Variable Speed 90V
- 38 Throwing Wheel
- 39 Ball Chute
- 43 Wheel Guard (ea.)
- 49 Grommet, Wiring
- 50 Plate, Travel Lock, and Elevation Control
- 60 Plate, Control, Panel Cover
- 61 Knob, Speed Control
- 63 Controller Assembly
- 64 Safety Reset
- 65 On/Off Switch

Exploded View

Inside/Outside
Figure 18

PARTS LIST

REF#s	HA BASE-BALL PART#s	DESCRIPTION
39	533-1307	Ball Chute
1	280-1003	Cane Tip ea.
35	533-0002	Clamp, Cable
63	530-0006	Controller Assembly
30	531-1505	Fitting, Elevation Control
49	280-3007	Grommet, Wiring
31	531-1504	Handle, Elevation Control
13	533-0500	Horizontal Swivel Lock Handle
61	280-2003	Knob, Speed Control
2	532-0001	Leg, Standard Size ea.
37	530-1012	Motor, Variable Speed 90V
65	223-0004	On/Off Switch (Rocker)
old	223-0002	On/Off Switch (Old Style - Toggle)
	232-0000	Power Cord (US)
64	232-0002	Safety Reset
old	232-0007	Safety Reset (Old Style Breaker)
14	533-0501	Swivel Lock Pivot
30B	310-0021	Tension Spring, Elevation Control
38	531-0001	Throwing Wheel
19	281-0002	Travel Wheel ea.
	281-0001	Travel Wheel, Extra-Heavy Duty

**To order additional parts,
please call:**

Sports Attack Customer
Service Department
Ph 800-717-4251
Fx 775-345-2883