

**NEW!**  
**ELITE**  
**TEAM**  
**FEEDER™**

**BASEBALL & SOFTBALL**

FEEDER



**New!**  
**Elite Feeder App**



**ELITE TEAM BALL FEEDER**  
PATENTS PENDING

**INSTRUCTION MANUAL**

OPERATION · SETUP · USE & CARE · SERVICE



SPORTS ATTACK LLC. | 800.717.4251 | [www.sportsattack.com](http://www.sportsattack.com)

# WARRANTY STATEMENT

What is most important to Sports Attack is that your machine meets your expectations and represents our high standards of quality and performance. No matter the circumstances, if this is not the case, we encourage you to call our customer service department at 800.717.4251.

## Warranty:

### Residential & Institutional

We stand behind the material and workmanship of our machines as well as all wear components (i.e., throwing wheels, controllers, and motors) for a period of two (2) years from the date of original purchase based on the serial number and date codes on the unit.

### Commercial

We stand behind the material and workmanship of our machines as well as all wear components (i.e., throwing wheels, controllers, and motors) for a period of one (1) year from the date of original purchase based on the serial number and date codes on the unit.

### Requirements of the Warranty

- Warranty wear components such as motors, controllers and wheels may now require a picture or live video when submitting your request.
- The serial number that represents the date of original shipment must be legible on the Product, it cannot be removed or altered in any way.
- All date codes on unit components must be legible, not removed or altered in any way.
- If warranty components have previously been provided by Sports Attack for the unit, video evidence of their use on the machine must be provided when submitting your request.

### Not Included in this Warranty:

- Normal wear and tear;
- Cosmetic damage (i.e., minor scratches, surface deformations, or discolorations) including natural fading of colors;
- Damage caused by misuse, abuse, accident or negligence including prolonged exposure to inclement weather;
- Damage caused by fire, flood or any other Act of God;
- Unauthorized modification or alteration of a machine including the use of non-authorized, after market components; and
- Any damage or failure arising after the warranty period.

### The Warranty Process

If you encounter any issues during the warranty period, Sports Attack will quickly get your machine back in working order. To submit a warranty request, you must call our customer service department at 800.717.4251. If the warranty repair involves a replacement part, we will make sure you get both the part and easy instructions for replacement at no cost to you.

### Returns

Sports Attack manufactures the highest quality sports training equipment in the world. If for any reason you are not satisfied, a machine can be returned within 30 days of receipt, for any reason, for a full refund less a 15% restocking fee. Cost of shipping the unit back to Sports Attack will also be the responsibility of the purchaser. Please note that the refund amount may be reduced by any non-cosmetic damage to the machine.

**Please call customer service department at 800.717.4251 for returns.**

## SHIPPING DAMAGE CLAIMS PROCEDURE

**NOTE:** For your protection, please note that equipment in this shipment was carefully inspected and packaged by skilled personnel before leaving the factory.

Upon acceptance of this shipment, the transportation company assumes full responsibility for its safe delivery.

### IF SHIPMENT ARRIVES DAMAGED:

1. **VISIBLE LOSS OR DAMAGE:** Be certain that any visible loss or damage is noted on the freight bill or express receipt, and that the note of loss or damage is signed by the delivery person.

(cont. on page 1)

**To register the Warranty, please return the Warranty Registration Card to:**

Sports Attack LLC.  
P.O. Box 1529  
Verdi, NV 89439

**For repairs and service after the Warranty period, please call:**

Sports Attack  
Customer Service Dept.  
Ph 800.717.4251  
Fx 775.345.2883

## RETURNS

**To return an item, please contact our Customer Service Department at 800.717.4251.**

A 15% restocking fee will be charged for any items accepted for return. It is the customer's responsibility to handle the repacking and shipment (as well as all associated fees) back to Sports Attack.

No returns will be accepted after 30 days of receiving this product.

2. FILE CLAIM FOR DAMAGE IMMEDIATELY: Regardless of the extent of the damage.
3. CONCEALED LOSS OR DAMAGE: If damage is unnoticed until the merchandise is unpacked, notify the transportation company or carrier immediately, and file "CONCEALED DAMAGE" claim with them. This must be done within fifteen (15) days from the date the delivery was made to you. Be sure to retain the container for inspection.

Sports Attack LLC. cannot assume liability for damage or loss incurred in transit. We will, however, at your request, supply you with the necessary documents to support your claim.

## INTRODUCTION

Thank you for purchasing this Sports Attack LLC. equipment.

Proper assembly, careful operation and consistent maintenance of this equipment will ensure that it gives you the very best performance and a long, economical service life.

This manual contains the information needed to properly set up the Elite Elite Team Ball Feeder, and to use, care for and maintain the Elite Team Ball Feeder, in a manner which will ensure its optimum performance.

## RECEIVING THE PRODUCT

Please check the contents of your boxes to ensure you have received all parts for the feeder.

If anything is missing or damaged, call Sports Attack Customer Service at 800-717-4251. If the product or package has been damaged in shipping, note on shipping tag, save all evidence of damage along with related documents and contact the shipper immediately.

See page 5 for Assembly instructions.

## TABLE OF CONTENTS

Warranty Statement . . . . .	i
Elite Team Ball Feeder Safety Instructions . . . . .	2
Elite Team Ball Feeder Features & Operational Controls . . . . .	3
Elite Team Ball Feeder Assembly . . . . .	4-6
Elite Team Ball Feeder Operation . . . . .	7-8
Download the <b>NEW! Elite Feeder App</b> . . . . .	8

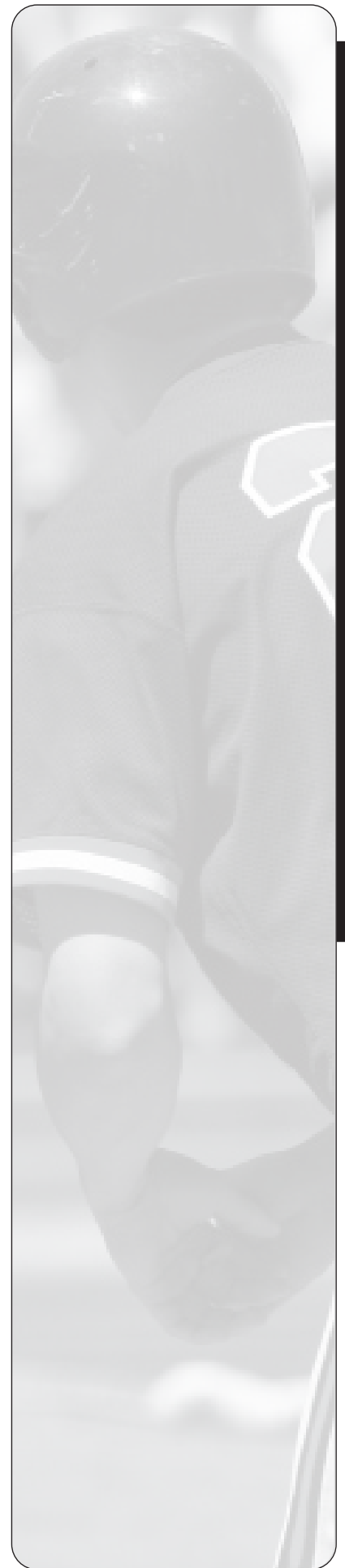

# SAFETY INSTRUCTIONS

## ELECTRICAL SAFETY

Use a 115 volt single phase 3-wire (2 wire with ground) grounded power source.

Up to 200 ft. from power source, use a minimum #14/3 grounded 3-wire 15 amp minimum rating extension cord.

Over 200 ft. from power source, consult a licensed electrician for required power cord size.

## OPERATING SAFETY

**CAUTION:** Carefully check Elite Team Ball Feeder for completeness and condition before connecting to electrical power:

1. Drive belt must be in alignment with motor pulley.
2. Make sure rear leg is aligned with both front legs (see Fig. 1).
3. Check to make sure the hitter's warning light is on whenever feeder is plugged in.
4. Never cross home plate when the warning light is "ON".
5. When warning light is "ON," be ready for a pitch.
6. Occasionally the Elite Team Ball Feeder may skip a pitch. Be alert for the following pitch.
7. It is possible that the Elite Team Ball Feeder could skip a pitch at the end of its supply of balls causing the hitter to think the last ball has been delivered. Always be prepared for a pitched ball as long as the light is "ON" and the feeder is in operation.
8. Use protective screen in front of pitching machine. Make sure it is tall enough to also protect the feeder.
9. Test pitches before allowing a hitter to enter the batter's box.

Carefully check the Elite Team Ball Feeder frequently for cleanliness, chips and cracks. Do not use if damaged. (For damage within Warranty period, see Warranty Statement, page i.)

10. Secure spare remote control in a safe location. Never use both remotes at the same time.
11. Remote control operates by radio frequency signal (RF). It is unlikely, but possible for the feeder remote to receive an errant RF signal from a source other than the intended remote.
12. Always turn off the feeder and pitching machine when not actively in use.

**Do not allow anyone to walk in front of the machine if it is connected to electrical power.**

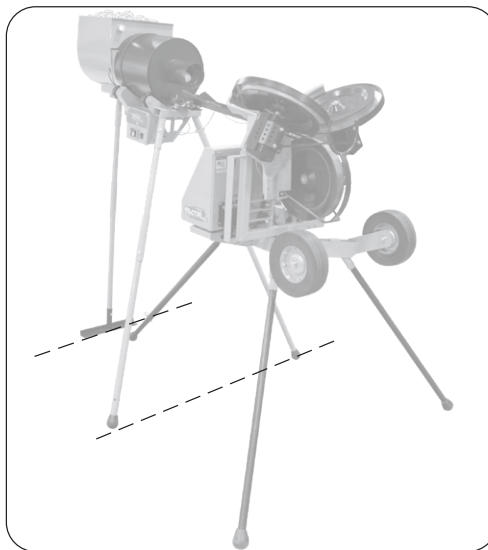

Fig. 1 Rear leg is parallel to the front legs.

## WARNING PERSONAL INJURY HAZARD

Carefully read all instructions in this manual, and all labels and warnings on Elite Team Ball Feeder before using this machine.

Use machine only under adult supervision. Failure to operate Elite Team Ball Feeder as described in this manual can result in severe personal injury or death.

## ELECTRICAL SHOCK HAZARD

Elite Team Ball Feeder must be connected to a properly grounded electrical receptacle.

Do not operate on wet ground.

## CAUTION PERSONAL INJURY HAZARD

DO NOT allow anyone to walk in front of the machine if it is connected to electrical power.

Carefully check Elite Team Ball Feeder for completeness and condition before connecting to electrical power.

At all times when the green warning light is "ON" it is possible a ball will be pitched. Be alert.

## EQUIPMENT ELECTRICAL DAMAGE

DO NOT plug in or energize this equipment until all Assembly Instructions (see pages 4-6) and Operation Instructions (see page 7) are read and followed.

# FEATURES & OPERATING CONTROLS

## Elite Team Ball Feeder

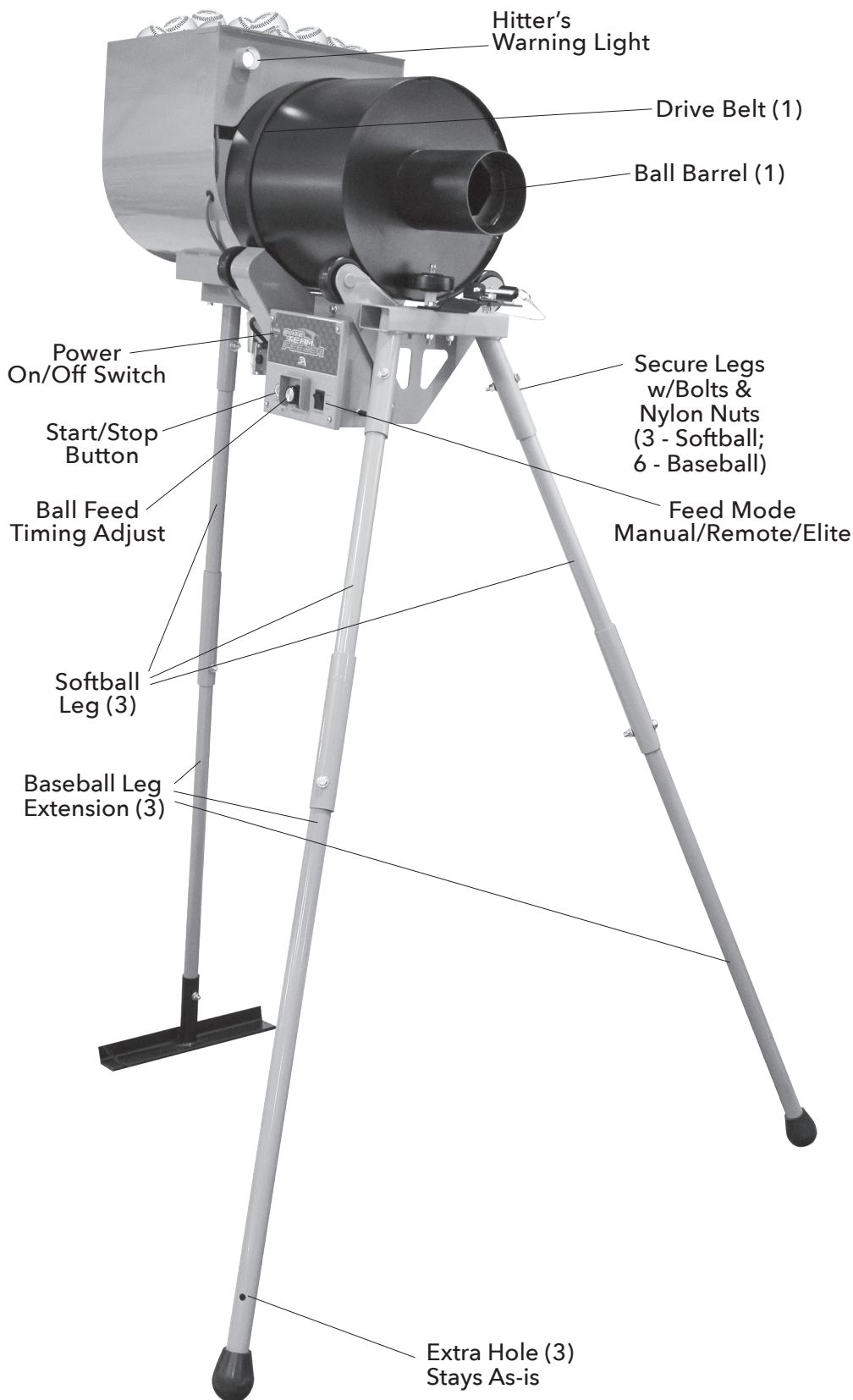

### Not Shown:

- Ball Feed Chute (1)
- Feed Tray (1)
- Manual

### INCLUDED MATERIALS

#### Baseball

Qty	Item
6	$\frac{5}{16}$ " x 2" Bolts
6	$\frac{5}{16}$ " Nylon Nuts

#### Softball

Qty	Item
3	$\frac{5}{16}$ " x 2" Bolts
3	$\frac{5}{16}$ " Nylon Nuts

### TOOLS REQUIRED

Qty	Item
2	$\frac{1}{2}$ " Wrenches or wrench and socket-ratchet combo.

### For missing parts, please call:

Sports Attack  
 Customer Service Dept.  
 Ph 800-717-4251  
 Fx (775) 345-2883

### ELITE TEAM BALL FEEDER

## Elite Team Ball Feeder ASSEMBLY

Your Elite Team Feeder will arrive fully assembled and strapped to pallet.

1. Remove straps from the machine
2. Install the machine legs (3).
5. Remove ball feed chute from pitching machine and install feed chute supplied with the Elite Team Ball Feeder.
6. Assemble ball feed tray. See page 6.

**NOTE:** The Team Feeder is supplied with one (1) ball feed chute.



Figure 3 Team Feeder on pallet

### CAUTION PERSONAL INJURY HAZARD

Use of the softball feeder on a machine set up for baseball could result in equipment damage and/or personal injury.

# Elite Team Ball Feeder BALL TRAY ASSEMBLY

Installing the ball tray assembly for the Elite Team Feeder.

## MATERIAL

1. Install the bracket and the two (2) mounting bolts to the team feeder, make sure to include locking pin with lanyard as shown (See Figure 4A).
2. Using the ½ inch wrenches or ratchet, attach the bracket to the team feeder (See Figure 4A below). The Team Feeder is now ready to attach to your pitching machine.
3. Line the team feeder up directly behind the pitching machine, leaving enough space between the chute and the bracket to allow for the tray that will carry the balls to the machine.
4. Next, remove feeder chute from the Elite Pitching Machine and install the feeder chute that is provided for the Team Feeder (See Figure 4B).

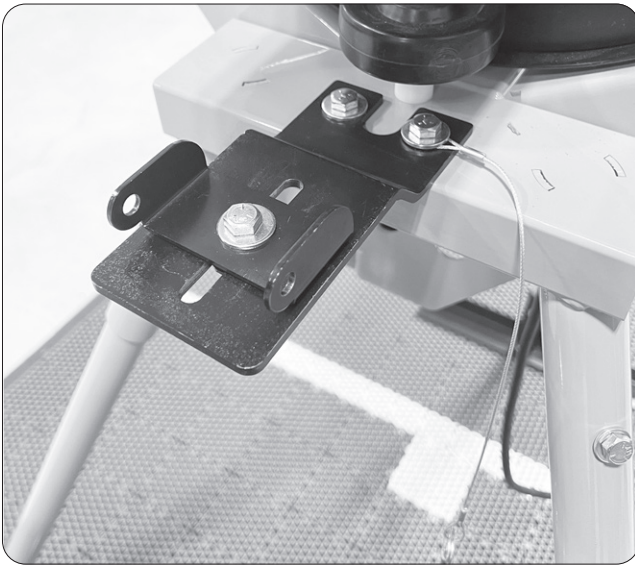

Figure 4A Attaching bracket.



Figure 4B Install feeder chute to Elite Pitching Machine as shown.

## INCLUDED MATERIALS

Qty	Item
1	Feeder Chute
2	5/16" x 2 1/4" Mounting Bolts
1	Tray
2	5/16" USS Washer
1	5/16" Nylon Lock Nut
1	Mounting Bracket (ball tray to feeder)

## TOOLS REQUIRED

Qty	Item
2	½" Wrenches or wrench

### To order additional parts, please contact:

Sports Attack  
Customer Service Dept.  
Ph 800.717.4251  
Fx 775.345-2883

## Elite Team Ball Feeder ASSEMBLY (cont'd)

5. Align ball feed tray and Elite Team Ball Feeder to pitching machine. (See Figures 5A and 5B). When aligning the Elite Team Ball Feeder, ball feed tray and pitching machine, make sure the hitter's warning light will be visible to the batter while they are practicing.
6. Connect ethernet cable from back of feeder control box to back of Elite Machine control box. (See Figure 5C).



Figure 5A Align ball feed tray under Elite Team Ball Feeder.

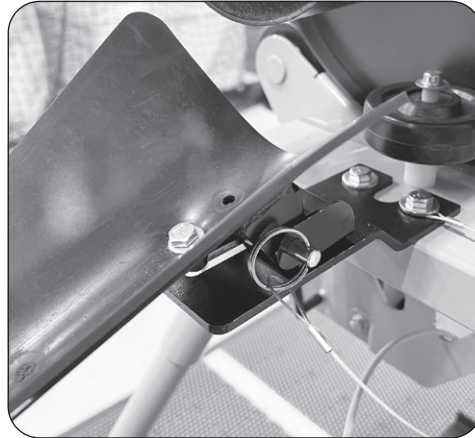

Figure 5B Align ball feed tray from Elite Team Ball Feeder to pitching machine (Side View).

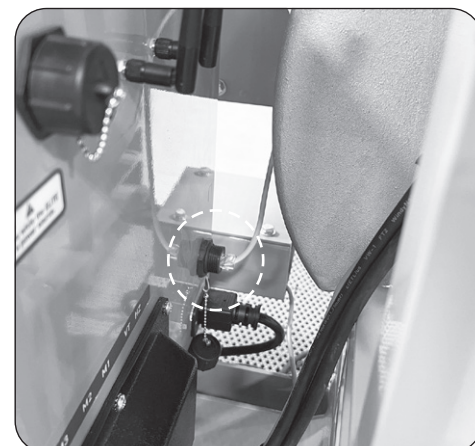
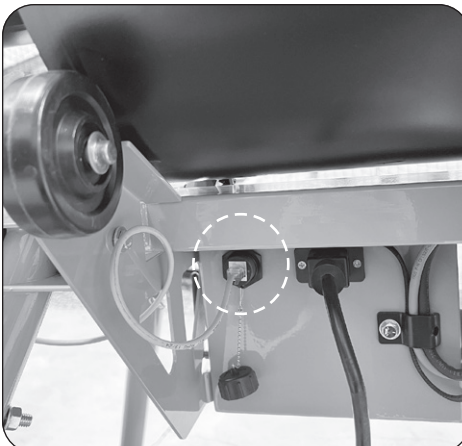
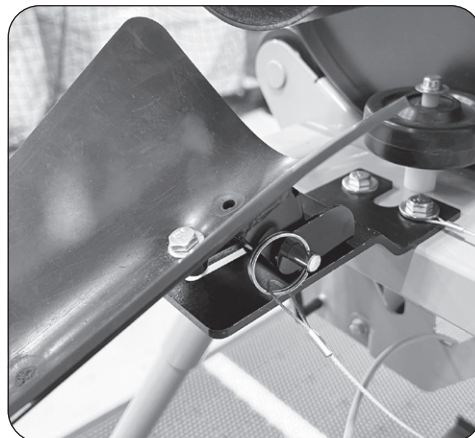

Figure 5C Connect ethernet cable to Elite Team Feeder and Elite machine.

**NOTE:** The Team Feeder is supplied with one (1) ball feed chute.

### CAUTION PERSONAL INJURY HAZARD

Use of the softball feeder on a machine set up for baseball could result in equipment damage and/or personal injury.

#### To order additional parts, please contact:

Sports Attack  
Customer Service Dept.  
Ph 800.717.4251  
Fx 775.345.2883

## Elite Team Ball Feeder OPERATION

- Ensure that your Elite is updated to version 2.0.1 or later.
- Once the Feeder is set up and the cable is connected from the Feeder to the Elite, turn on the Elite and the Feeder by turning the power switch on each to "ON".
- For the initial "Test Pitches", grab a handful of balls, and align multiple pitches to the center of home plate. Or, switch your feeder into "Remote Mode" then press and hold LED button until the LED turns green.
- Ensuring there is no one in the line of sight of the machine, either put balls into the chute or press the remote button to send a ball. Once you are finished with alignment, put the feeder into "Elite Mode".
- Select "Connect to Feeder".

### MANUAL MODE

- Connect to power source.
- ENSURE THERE IS NO ONE IN THE MACHINES LINE OF SIGHT UNTIL SET UP IS COMPLETE!
- Turn power switch on the left side of the control box to "ON".
- On the front control panel, set switch to "Manual Mode".
- The push button will light up with a red ring.
- Press the push button, it will turn green and begin rotating the drum.
- Use the dial on the control box to control the speed of the drum.
- Once the Feeder is feeding the machine at the desired pace, and the machine is pitching to the desired location, a hitter may begin training.
- To stop the Feeder, press the push button, the ring will turn Red, and the drum will stop rotating. You may also turn the power switch off.

### REMOTE MODE

- ENSURE THERE IS NO ONE IN THE MACHINES LINE OF SIGHT UNTIL SET UP IS COMPLETE!
- Turn power switch on the left side of the control box to "ON".
- On the front control panel, set switch to "Remote Mode".
- The push button will light up with a red ring.
- Press the push button, it will turn green.
- Grab your remote and press the button once. The drum should rotate a single revolution. It may rotate less than half a revolution and NOT drop a ball. This is OKAY, as the sensor is just finding the "Home" location.
- Continue to press the button a single time, whenever you would like a ball to be delivered.
- If you would like the drum to rotate continuously, as if in manual mode, press and hold button on the remote until the LED light on control panel turns green. The drum will rotate until the remote button is pressed again.
- Use the dial on the control box to control the speed of the drum.
- When you are sure that the feeder is working as desired, and the machine is pitching to the desired location, a hitter may begin training.
- To stop the feeder when running continuously in the "Remote Mode", press the remote button once, press the bush button or set the power switch to "OFF"
- If your remote is not working:
  - If there is a red light that flashes when you press the remotes button, but it does not start rotation of the drum:
    - The remote needs to be paired with the Team Feeder:
- Ensure the Team Feeder is turned "ON"
- Set to "Remote Mode"
- PRESS AND HOLD the push button until the red light turns into a blinking blue light.
- PRESS AND HOLD the button on the remote.
- Once the blue blinking light has turned solid blue, release the remote button.
- Press the push button to turn it green and try remote use again.
  - If there is NO red light that flashes when you press the remotes button.
  - The remotes battery has died or is not properly connected.
- Open the back of the remote and insert two Triple-A batteries as shown on the remote.
- Try using it again.
- If this does not solve the issue call Sports Attack Technical Support 800.717.4251

**NOTE: When batteries are replaced, the remotes will have to be paired again.**

## CAUTION PERSONAL INJURY HAZARD

Elite Team Ball Feeder should be used under adult supervision only!

Use of the softball feeder on a machine set up for baseball could result in equipment damage and/or personal injury.

Any time the hitter's warning light is "ON" or the Elite Team Ball Feeder is turning, a pitch may be delivered.

**Be alert at all times.**



The LED Pushbutton

The LED Pushbutton has several different color codes to denote different operations or error codes:

- Red**= Feeder inactive but powered on
- Flashing Red**= Error code (# of flashes determine error) CALL SPORTS ATTACK
- Green**= Feeder is active and ready
- Light Blue/Cyan**= Single ball being fed
- Blue Flashing**= Bluetooth pairing is active
- No color**= Feeder is without power

NEVER ALLOW A PERSON TO WALK IN FRONT OF THE MACHINE OR FEEDER AS LONG AS IT IS POWERED ON! TURN THE POWER SWITCH OFF BEFORE ALLOWING PEOPLE TO WALK IN FRONT OF THE MACHINE.

Download the Elite Feeder App below.



Android and Google Play are registered trademarks of Google Inc. in the United States and other countries.  
iPhone and Apple Store are trademarks of Apple Inc., registered in the U.S and other countries. Other names may be trademarks of their respective owners.

From your phone or tablet, using Bluetooth, wirelessly control your Elite eHack Attack and your Elite Feeder.

### Using the Elite Feeder via App control

- o Download the Elite Feeder App
- o Repeat steps above until you complete the "Test Pitch"
- o Select "Connect Via App"
- o Open the Elite Feeder App and select "Connect to Feeder"
- o Select "Start Scan"

**NOTE: YOU MUST ALLOW "SCAN FOR DEVICES" AND "ACCESS TO CAMERA"**

- o Your Elite will show the serial number on the screen, select the matching serial number shown on the app.
- o Once a connection is made, a unique QR code will appear on the Elite. Scan it with your app, this ensures that only one device may be connected at a time.
- o You will have access to "Standard Pitches", "Favorite Pitches" and "Favorite Sequences".
- o Standard Pitches will allow access to pre-programmed pitches that you can adjust the speed on. Simply press "Pitch" once the button has lit up and a ball will be released.
- o Favorite Pitches will allow access to all pitches that have been saved to favorites on the machine. Simply select the pitch you would like to throw, and press "Pitch" once the button has lit up.
- o Favorite Sequences will allow you access to the sequences that were saved on the machine. Select the mode you would like to run it in ("Run", "Random", "Repeat", etc.)
- o Once the machine is ready a "Start" button will light up. Select that, and the machine will feed through the sequence in the mode that it is being run in.
- o Press "Pause" to pause the sequence in its current state. You may then select "Resume" or back out to a different page.

•NOTE!!! "Random" and "Repeat" mode will continue running until the user selects "Pause" or backs out of the page! NEVER allow a person to walk in front of the machine if it is powered on.

•NOTE!!! On rare occasion, the feeder may skip a ball, this does not necessarily mean that the feeder is out of balls. Ensure that the machine is off before collecting balls!

•NOTE!!! You may not modify pitches or add pitches to favorites or sequences while connected to the feeder. You must use the Elite in its standard mode to modify pitches or sequences!

## GENERAL OPERATION

1. Do not mix different types of balls.
2. ALWAYS use protective screen to protect Team Feeder from batted balls and line drives or void warranty.

## CAUTION PERSONAL INJURY HAZARD

Elite Team Ball Feeder should be used under adult supervision only!

• Use of the softball feeder on a machine set up for baseball could result in equipment damage and/or personal injury.

• Any time the hitter's warning light is "ON" or the Elite Team Ball Feeder is turning, a pitch may be delivered.

Be alert at all times.